

Li-ion Battery Specifications

Model No. : 0203BF01
Description : 2S3P Li-ion Battery Hard Pack
Battery CELL : NCR18650BF (Panasonic)
Date : 2022.10.11



Battery Pack Specifications

Feature	Specifications
Pack configuration	2S3P
Pack nominal voltage	7.2V
Pack rated capacity	9600mAh
Watt-Hour	72Wh
Maximum Charging Current	5.0A
Continuous Discharge Current (Max)	8.0A
Charge connector	AMP 787614-1 5-pin
Discharge connector	
Case	Plastic case(Sabic 6600)
Communication interface	SMBus support
Dimension	134.5*80*22.5±1mm
Weight	0.350KG±50g
Certification	UN38.3 / IEC62133 / IEC60601-1-2
Applicable charger	Available

BMS Specifications

No.	Item	Specification	Remark
1	Model	PCB4S	
2	Over charge voltage threshold	4.25V±0.025V	
3	Over charge voltage release	4.0V±0.05V	
4	Over discharge voltage threshold	2.70V±0.050V	
5	Over discharge voltage release	3.0V±0.100V	
6	Over discharge current threshold	9A±1%	
7	Over current delay time	2S	
8	Short circuit threshold	50A	
9	Balance function	Enabled	

All specifications are subject to change without notice.

Mechanical Drawing

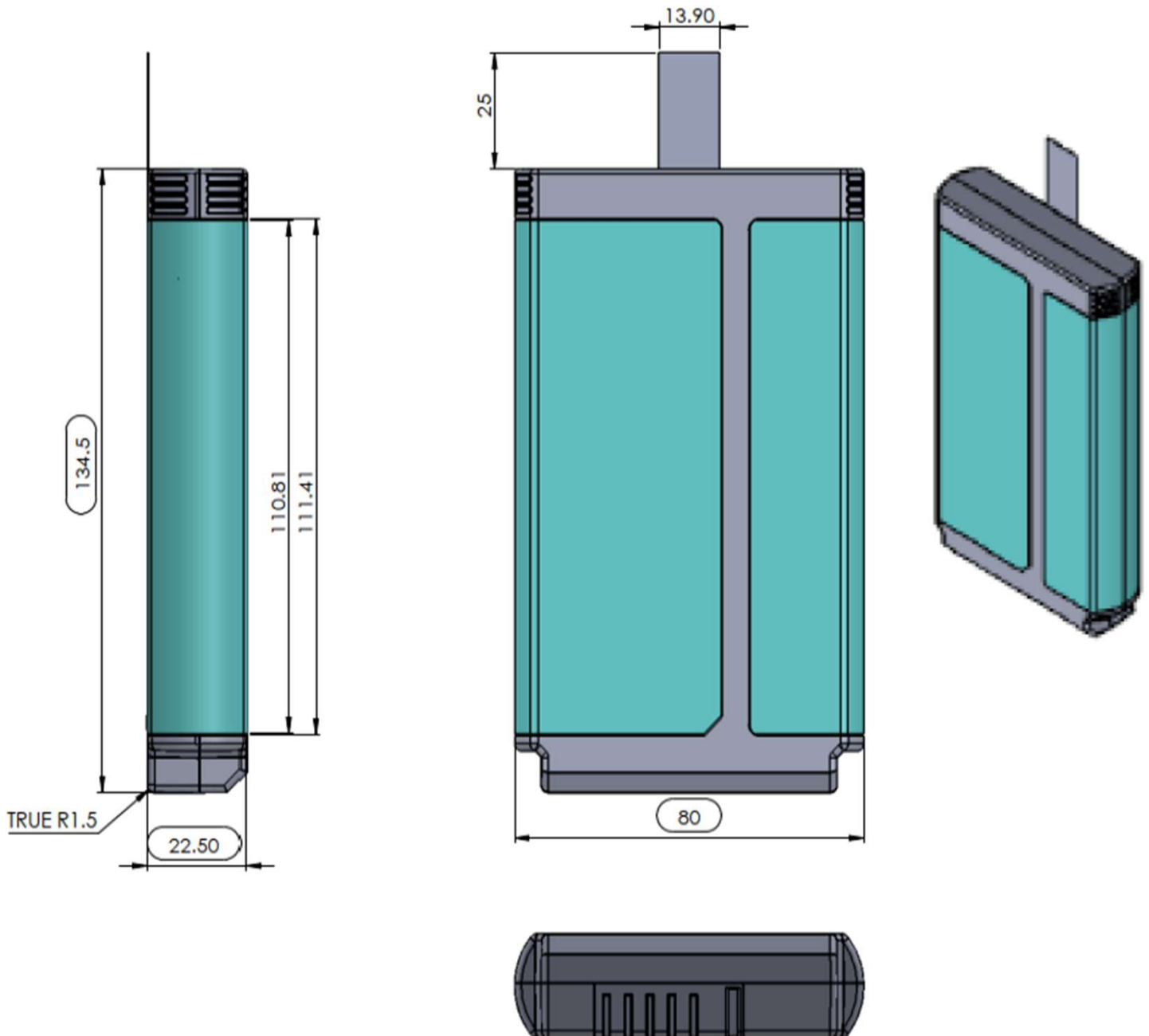

専用充電器



主な仕様:

構成	専用充電器+ACアダプタ
特徴	適用電池を2パック同時充電可能
充電電圧・電流 (常温)	2S2P: 8.4V 3.2A 2S3P: 8.4V 4.8A 2S4P: 8.4V 4.8A 3S2P: 12.6V 3.2A 4S1P: 16.8V 1.6A 4S2P: 16.8V 3.2A
出力端子	専用コネクタ (電池と勘合)
充電機能	CC-CV充電 保護機能あり
表示(LED)	緑点滅:充電中 / 緑点灯:充電完了 赤点滅:異常
充電時間	約 5時間 (常温にて)
寸法(充電器部)	190*100*97 mm
専用ACアダプタ	DC24V 6.6A 160W
適用安全規格 (ACアダプタ)	<PS>E IEC/EN/UL 62368-1 & 60950-1 CB / GS / CE / BSMI / RCM / CCC