

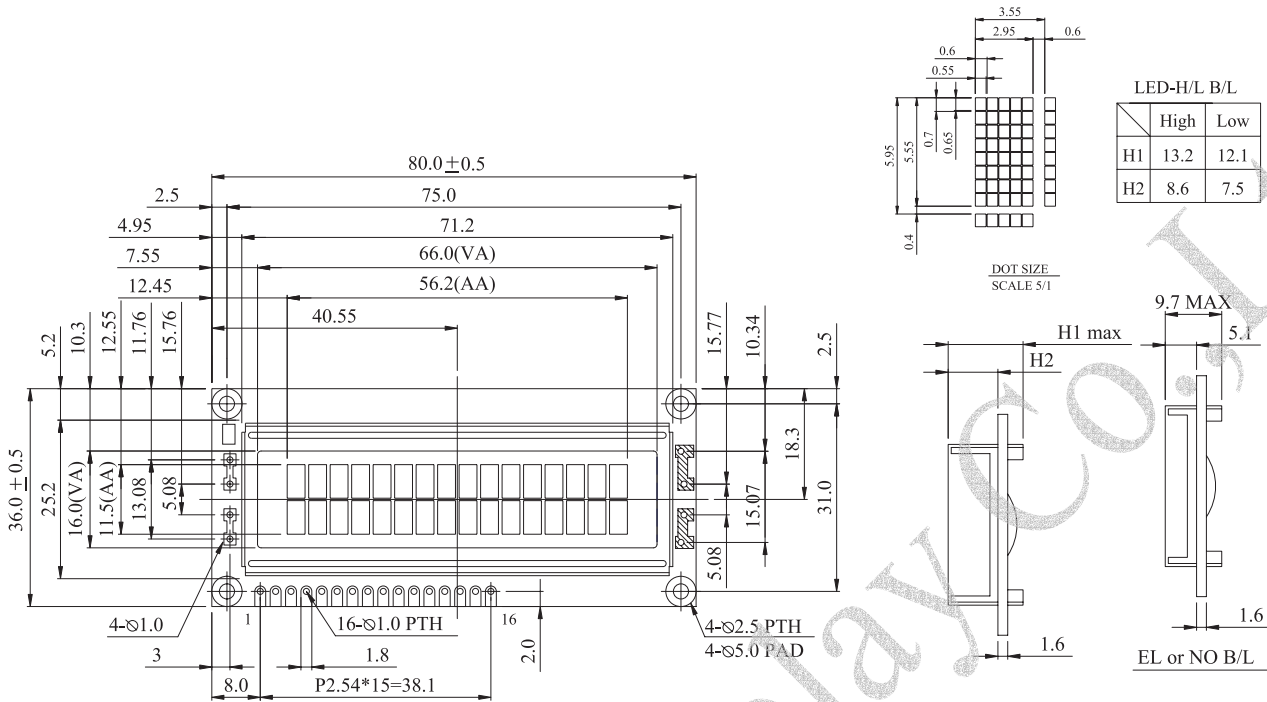

# WH1602J Character 16x2

## Dimension drawing



### Feature

- 5x8 dots includes cursor
- Built-in controller (KS 0066 or Equivalent)
- +5V power supply (Also available for +3V)
- 1/16 duty cycle
- LED can be driven by pin1, pin2, pin15, pin16 or A and K
- N.V. optional for +3V power supply
- Optional: smaller character size (2.95x4.35mm)

### Mechanical Data

Item	Standard Value	Unit
Module Dimension	80.0x36.0	mm
Viewing Area	66.0x16.0	mm
Mounting hole	75.0x31.0	mm
Character Size	2.95x5.55	mm

Pin NO.	Symbol	Function
1	Vss	GND
2	Vdd	+3V or +5V
3	Vo	Contrast Adjustment
4	RS	H/L Register select signal
5	R/W	H/L Read / write signal
6	E	H→L Enable signal
7	DB0	H/L Data bus line
8	DB1	H/L Data bus line
9	DB2	H/L Data bus line
10	DB3	H/L Data bus line
11	DB4	H/L Data bus line
12	DB5	H/L Data bus line
13	DB6	H/L Data bus line
14	DB7	H/L Data bus line
15	A/Vee	+4.2V for LED(RA=0Ω)/Negative Voltage output
16	K	Power supply for B/L (0V)

### Absolute Maximum Rating

Item	Symbol	Standard Value			Unit
		min.	typ.	max.	
Power Supply	VDD-VSS	-0.3	---	7.0	V
Input Voltage	VI	-0.3	---	VDD	V

Note : VSS=0 Volt, VDD=5.0 Volt.

### Electrical Characteristics

Item	Symbol	Condition	Standard Value			Unit	
			min.	typ.	max.		
Input Voltage	VDD	VDD=+5V	4.7	5.0	5.3	V	
Supply Current	IDD	VDD=5V	---	1.2	1.5	mA	
Recommended LC Driving Voltage for Normal Temp. Version module	VDD-V0	-20°C	---	---	5.2	V	
		0°C	---	---	4.2		
		25°C	---	3.8	---		
		50°C	3.5	---	---		
70°C	3.2	---	---				
LED Forward Voltage	VF	25°C	---	4.2	4.6	V	
LED Forward Current	IF	25°C	Array	---	100	---	mA
			Edge	---	20	40	
EL Power Supply Current	IEL	Vel=110VAC;400Hz	---	---	5.0	mA	

### Display Character Address Code :

Display position	1	2	3	4	5	6	7	8	9	10	11	12	13	14	15	16
DD RAM Address	00	01														0F
DD RAM Address	40	41														4F

Character type