

承 認 書

APPROVAL SHEET

CUSTOMER: MAP ELECTRONICS CO., LTD

CUSTOMER MODEL NO.: MEGWX-282XSAXX-920

DESCRIPTION #282X Replacement Antenna

REV.: 03

DATE 2015/9/9

Customer Approval	
-------------------	--



Index.

1. Specification	2
1.1 Drawing	2
1.2 Connector	3
<hr/>	
2. Test report	4
2.1 Electrical test	4
2.2 Pattern test	5

Modification History:

Rev.	Date	Content
00	2015/5/20	
01	2015/5/19	變更Body Material/Operating Temp
02	2015/8/19	新增 Wave Length,Type/Peak Gain
03	2015/9/9	變更電氣規格表

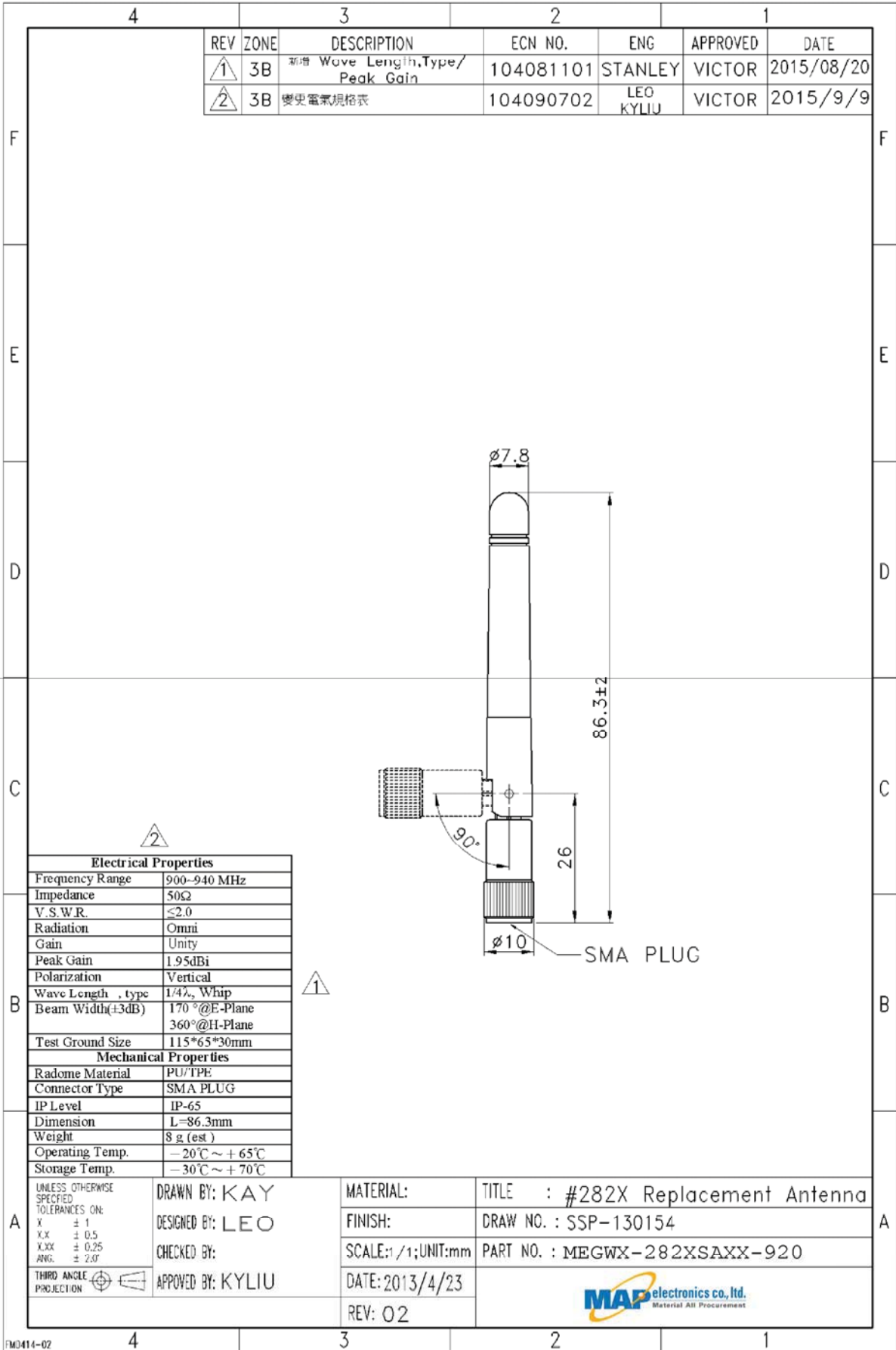

Connector		SMA
Specification Data	1) Impedance	50 ohm
	2) Frequency Range	0~6GHz
	3) V.S.W.R.	≤ 1.5
	4) Working Voltage	≤ 250 Vrms
	5) Dielectric Withstanding	≤ 670 Vrms
	6) Voltage Insulation Resistance	≥ 2000 Mega ohm
	7) Contact Resistance	Center contact: 3.0 Milliohms (Max.) Outer contact: 2.0 Milliohms (Max.)
	8) Recommended coupling nut torque	4.0~8.8 in. lbs (0.45~0.99Nm)
	9) Coupling nut retention force	≥ 50 lbs (222N)
	10) Contact captivation force	≥ 5 lbs (22.2N)
	11) Durability (mating)	≥ 500 cycles
Environmental Data	1) Operating Temperature	$-65^{\circ}\text{C} \sim +165^{\circ}\text{C}$
	2) Thermal Shock	MIL-STD-202, Method 107, Condition B
	3) Corrosion	MIL-STD-202, Method 101, Condition B
	4) Shock	MIL-STD-202, Method 213, Condition I
	5) Vibration	MIL-STD-202, Method 204, Condition D
	6) Moisture Resistance	MIL-STD-202, Method 106
Material Specifications	Material Data	Material
	1) Body	Brass
	2) Contact	Brass
	3) Insulator	Teflon or Delrin

Model. MEGWX-282XSAXX-920

Test Report

Return loss/V.S.W.R

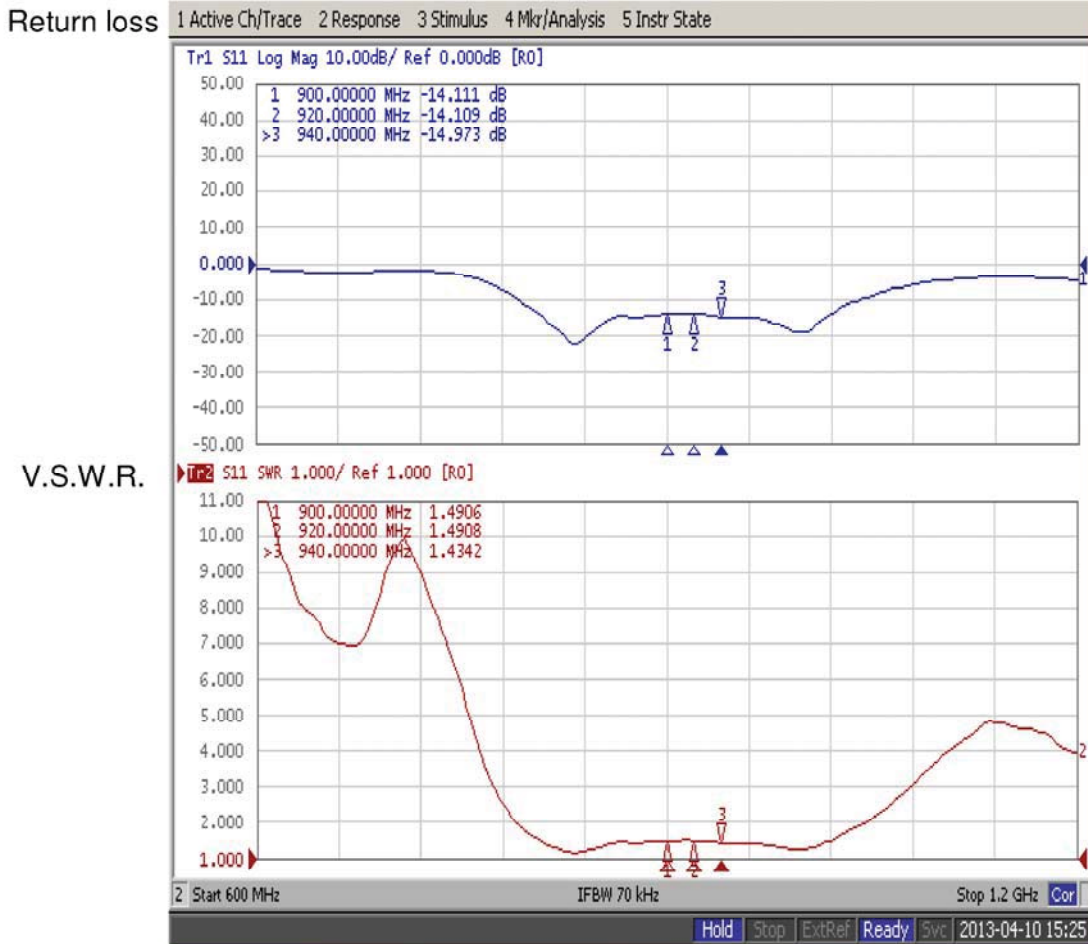

Model. MEGWX-282XSAXX-920

2D Patten Test Instrument

Pattern Test

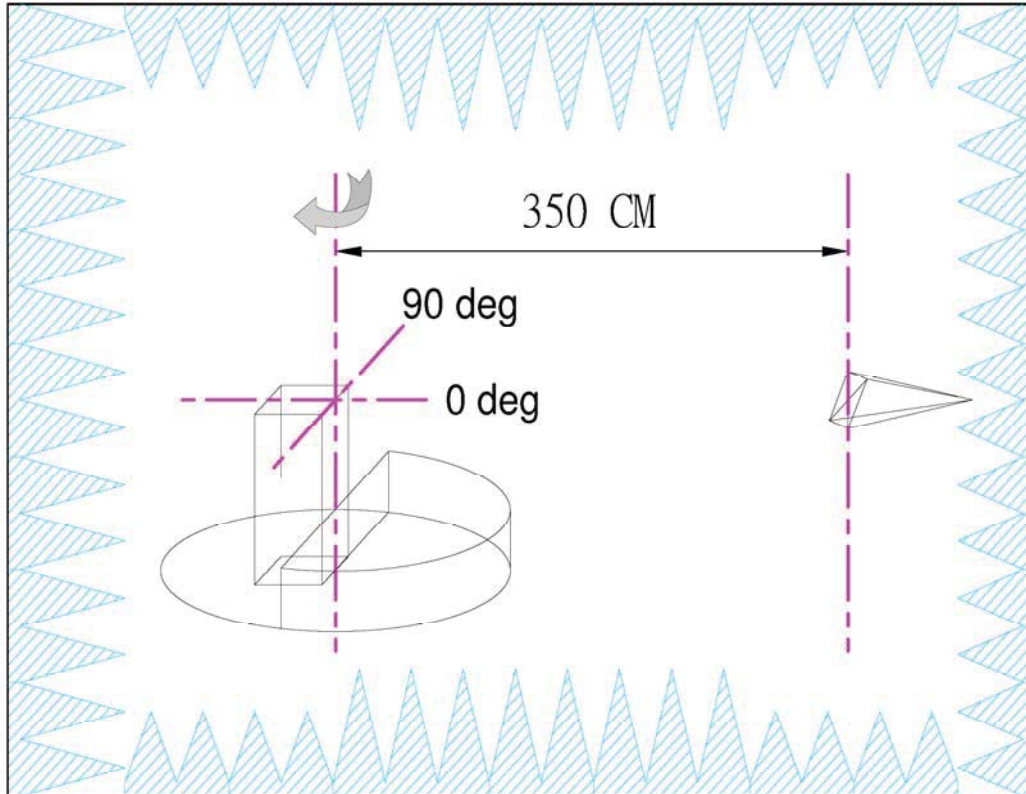

Test Equipment

Anechoic chamber: 100MHz~6GHz 8*6*6m (※ 1m Quiet zone at 800MHz)

Source Antenna: ETS-3164 Dual Polarized Horn

Network Analyzer: Agilent E5071B 100kHz~8.5GHz

Model. MEGWX-282XSAXX-920

2D Patterns

Pattern Test

E-plane

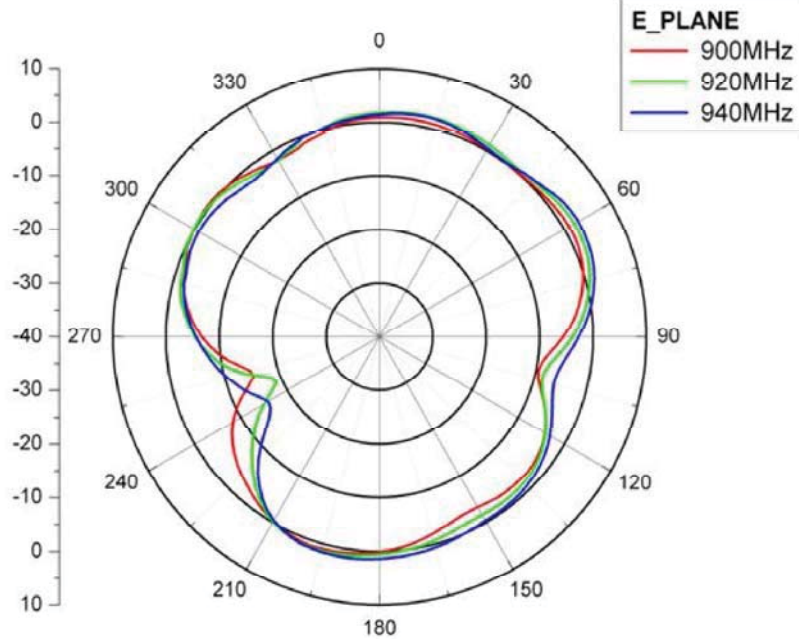

H-plane

