

*For reference only*

**Revisions**

Note: Revisions B; B-1; B-2..... On behalf of official Drawing.  
Revisions 1; 2; 3; 4..... On behalf of experiment's Drawing.

ISS	Symbol	Description	Date
1	1	The Original Design	2016/03/10
2	2	CHE IP Code IP68 was IP67; Add IPx8 Definition.	2016/03/20
B	B	Official Release	2016/05/11

**Notes :**

- Any Electrical, Mechanical or Environmental Test Per MIL-C-39012 Should be Spotlighted, as We May Not Have All Testing Equipment to Cover All of It.
- Single Crimp: Recommended Dimensions Provided for Ferrule.  
Dual Crimp: Recommended Dimensions Provided for Ferrule And Center Pin.  
Please Advise Single/Dual in Advance to Avoid Any Inconvenience.
- All Metal Materials Are in Compliance with RoHS 2 Directive 2011/65/EU Annex III Section 6 Paragraph.
- Recommended Crimped Hand Tool : for Center Pin P/N - **HT-801G**  
for Ferrule P/N - **HT-H116N**
- Waterproof Class : **IP68**
- This Connector Must Be Sealed thru Center Conductor to 5 PSI at 1 Meter under The Water Passed for 1 Hour Test. ( Equal to 4 Meters under The Water )**

**Electrical :**

Impedance : 50 ohm  
Frequency Range : 0~4 GHz .  
Voltage Rating :  $\geq 500$  V rms (depending on cable)  
Insulator Resistance :  $\geq 5$  G $\Omega$   
Dielectric Withstanding Voltage : 1500 V rms .  
Contact Resistance : Center Contact  $\leq 1.5$  m $\Omega$ .  
Outer Contact  $\leq 1$  m $\Omega$  .

**Mechanical :**

Mating : Bayonet Coupling.  
Recommended Mating Torque : 0.6~2.5 lbs  
Coupling Nut Retention Force :  $\geq 101.2$  lbs

**Environmental :**

Temperature Range : -65°C to 165°C  
Corrosion(Salt Spray) : MIL-STD-202, Method 101, Cond. B  
Thermal Shock : MIL-STD-202, Method 107, Cond. B  
Mechanical : MIL-STD-202, Method 213, Cond. G  
Vibration : MIL-STD-202, Method 204, Cond. B

**Finish :**[Unit of Plating Thickness Is in Micro Inch( $\mu$ )]

- Nickel Plating Thk. : 50  $\mu$ " min. (Under Plating)**
- Gold Plating Thk. : 2  $\mu$ " max. (Over Finish 1)**

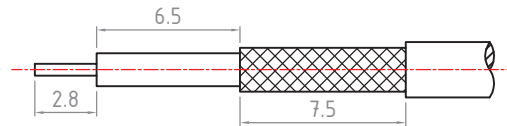
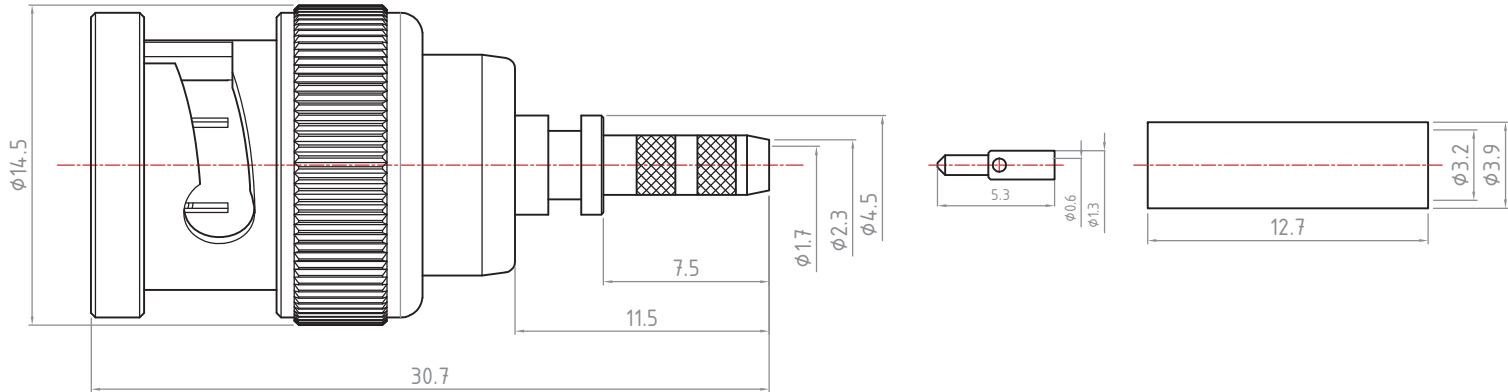

Recommended Cable Stripping Dimensions

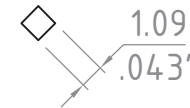

Recommended Crimping Dimensions for Inner Contact

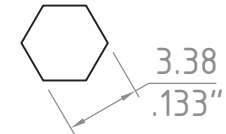

Recommended Crimping Dimensions for Ferrule

3	Ferrule	Brass	Finish 1			Scale	Abbr.	Date	Rev.	DWG. NO.	TITLE	RoHS 2
3	Ferrule	Brass	Finish 1			NTS	ST	2016/08/29	B	<b>B101P3N01-M</b>	BNC S/T Plug, Dual Crimp Type (IP68) for for RG174,188,316;B7805A;URM95 Cable	
3	Inner Contact	Brass	Finish 1/2			Tolerances : .X $\pm 0.2$ .XX $\pm 0.1$ .XXX $\pm 0.05$				Customer P/N:		
3	Insulator	PTFE	None			All Dimensions in mm (Unless Otherwise Specified)				<b>Proprietary Note</b> This document contains information proprietary to MAP, which is either copyrighted, or patent applied for, and / or protected by trade secret laws. This document or parts thereof, may not be used, disclosed or reproduced in any form by any method, or for any purpose, without the written permission of MAP, Japan.		
2	Body	Brass	Finish 1			Drawn	Checked	Approved				
1	Shell	Brass	Finish 1			<i>Louis</i>	<i>Ryan</i>	<i>G. Sun</i>				
ITEM	Description	Material	Finish	Part Number	QTY	2016/08/29	2016/08/29	2016/08/29				

